

A.01

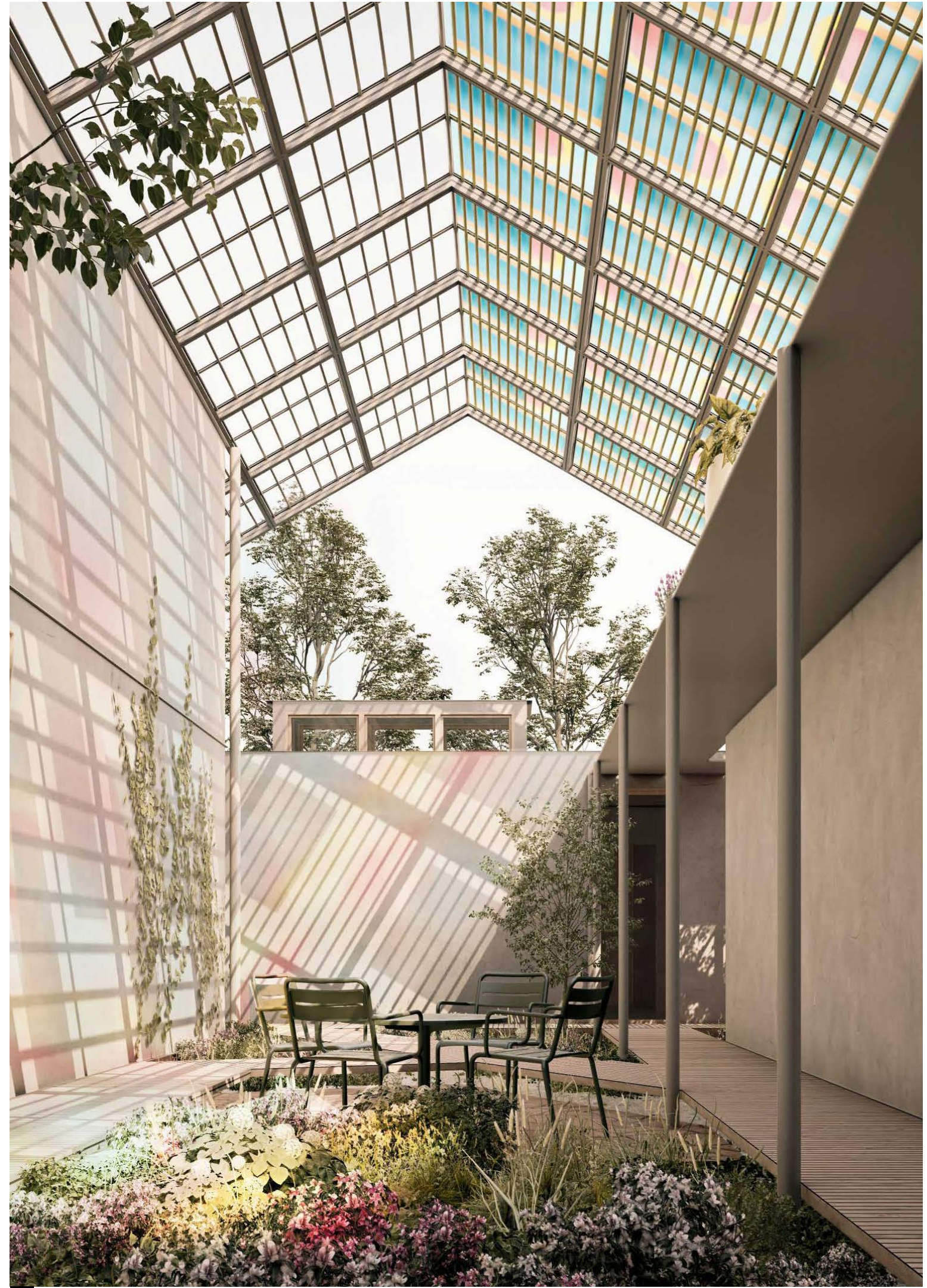

Title	All Under One Roof
Program	Multi-Family Residential
Zoning	RS-5
Status	Study
Location	Vancouver, B.C.
Size	4,340 sqf
FSR	0.7 x 6,250 sqf = 4,735 sqf permitted

South Elevation

Digital Image

A.01

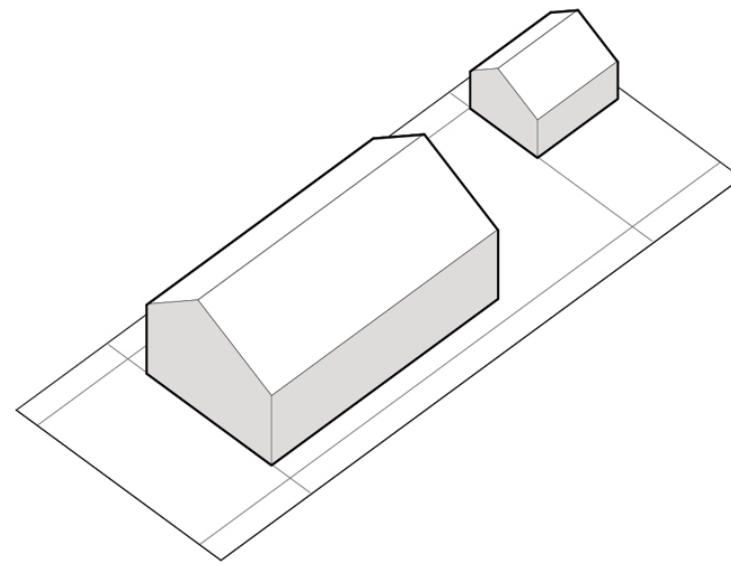

1 A typical single family home on the site
0.7 FSR x 6900 sqf = 4500 sqf

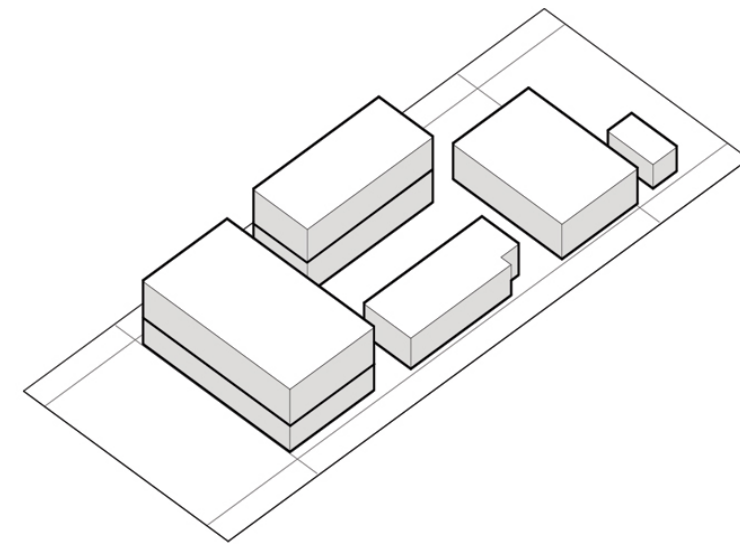

2 The same square footage arranged on site as 6 rental units.
0.7 FSR x 6900 sqf = 4500 sqf

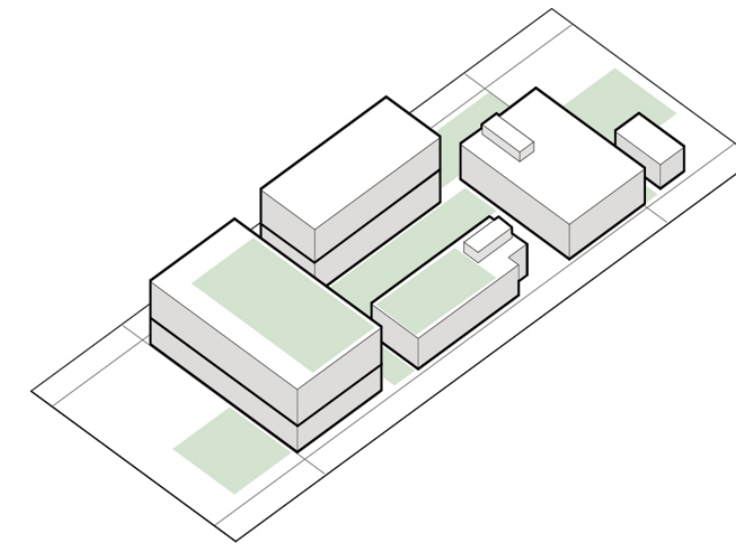

3 This arrangement creates a semi-enclosed for each unit.
1800 sqf of garden space

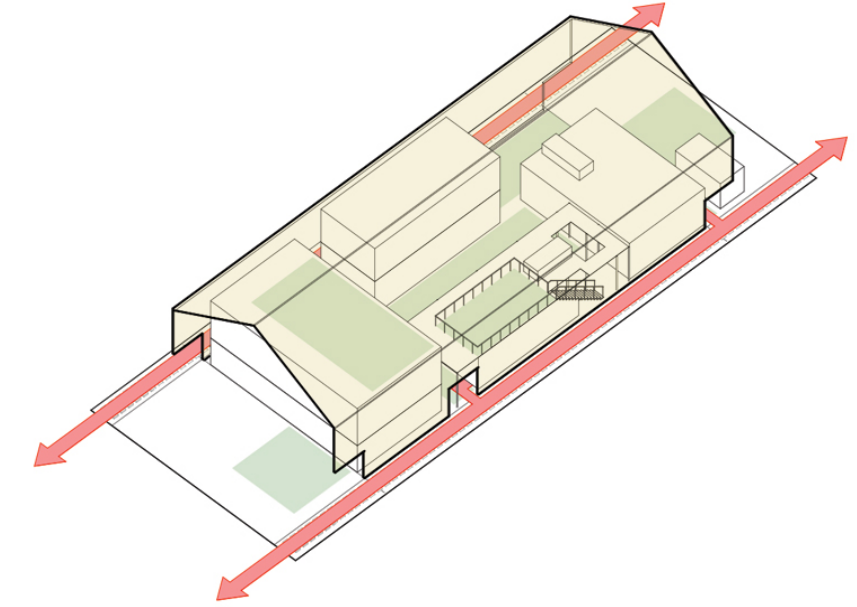

4 Circulation through the site is contained in the site setbacks, allowing the interior gardens to remain private.

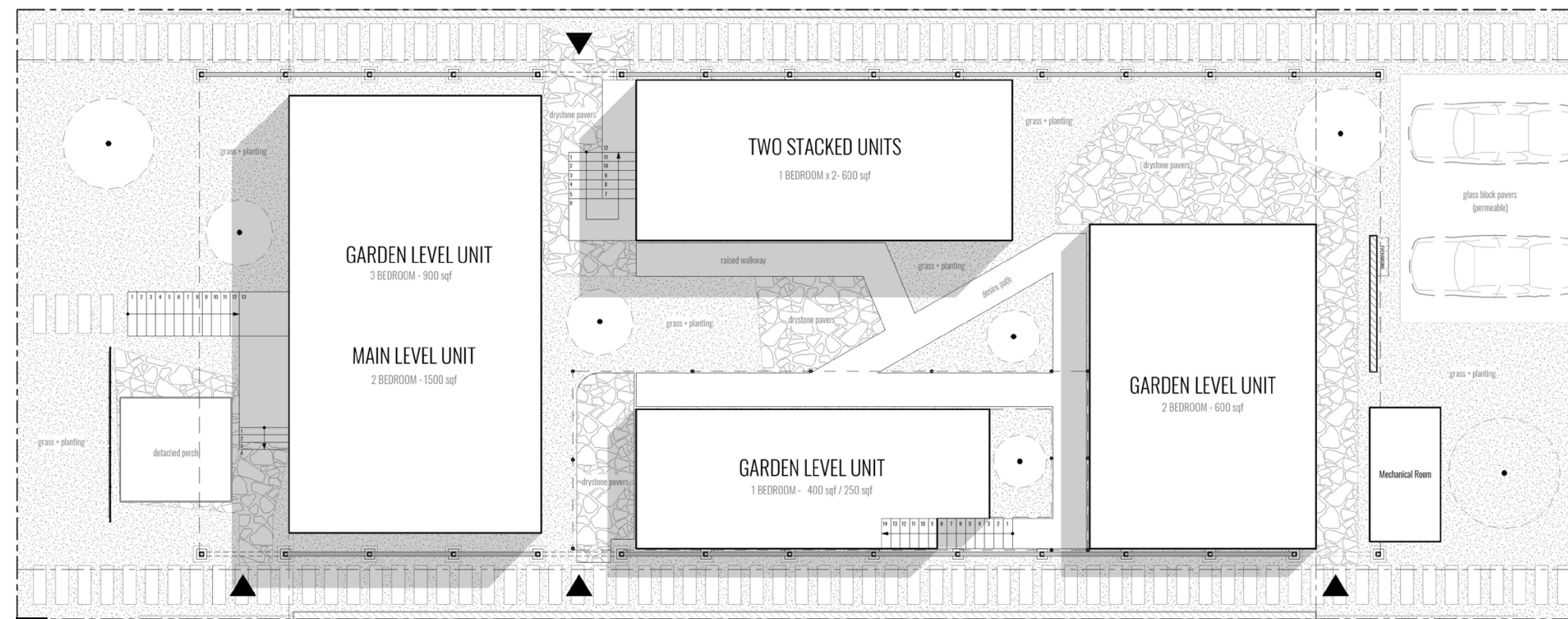

All Under One Roof is a response to the City of Vancouver's "Making Home" initiative to create housing options for middle income earners. This pilot program allows for six units on one site. In All Under One Roof, six units are arranged underneath a large climate canopy. All Under One Roof, is a reaction to the urgent need for densification as well as our increasingly volatile climate. The lightweight canopy structure supports solar louvres and PET Graphic Solar film. This solar system serves to mitigate heat, harvest energy and washes the site in colored filtered light. Under the canopy, a number of climate mediated outdoor spaces sit between the units. One for each unit. When entering the site, each inhabitant has a private entrance into the canopy which is accessed via walkways located within the site setbacks. This approach to circulation allows a high level of privacy for each of the climate mediated outdoor spaces. Raised walkways allow secondary movement across the interior of the site, which is landscaped with local trees and overgrown vegetation. Under The Canopy life thrives.

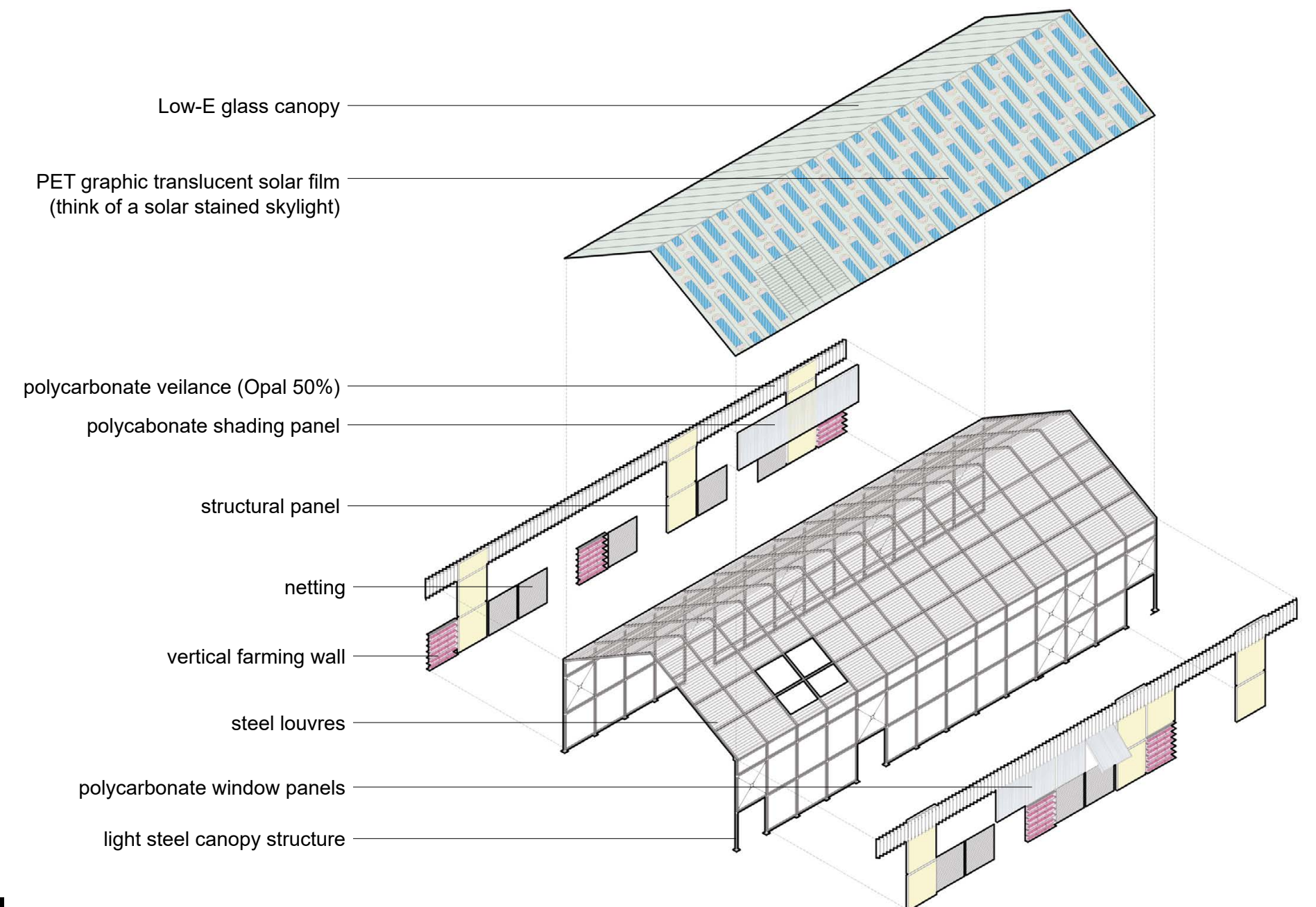

Massing Diagram

Climate Canopy Exploded Axo





A.01

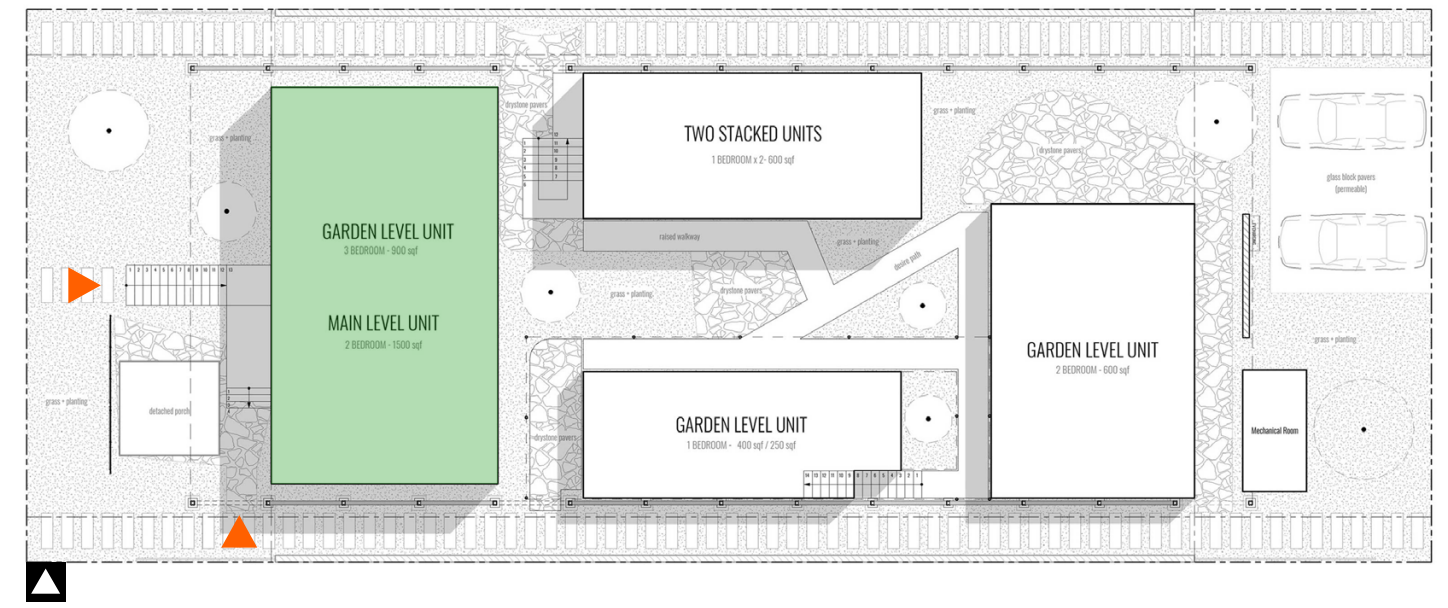
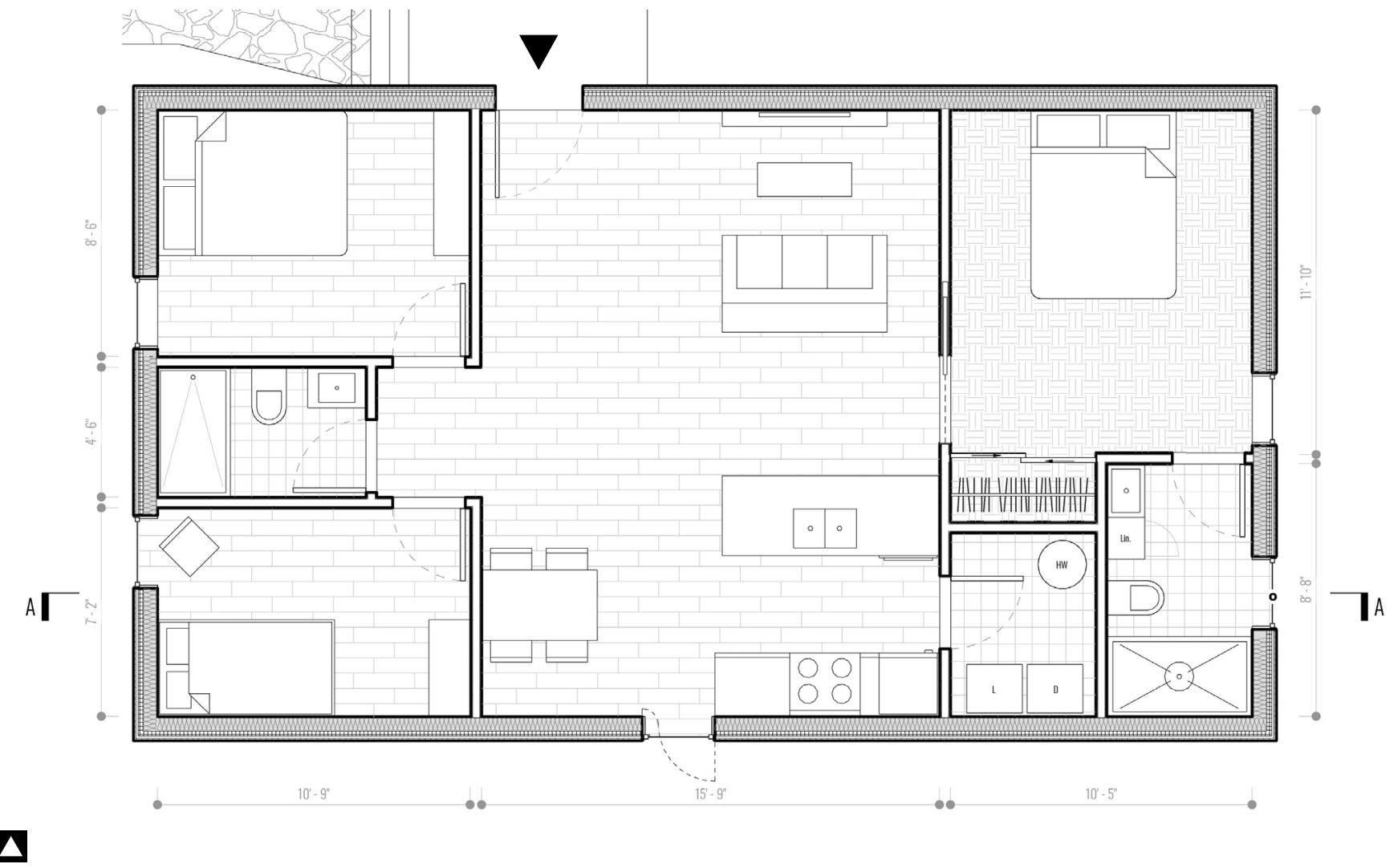
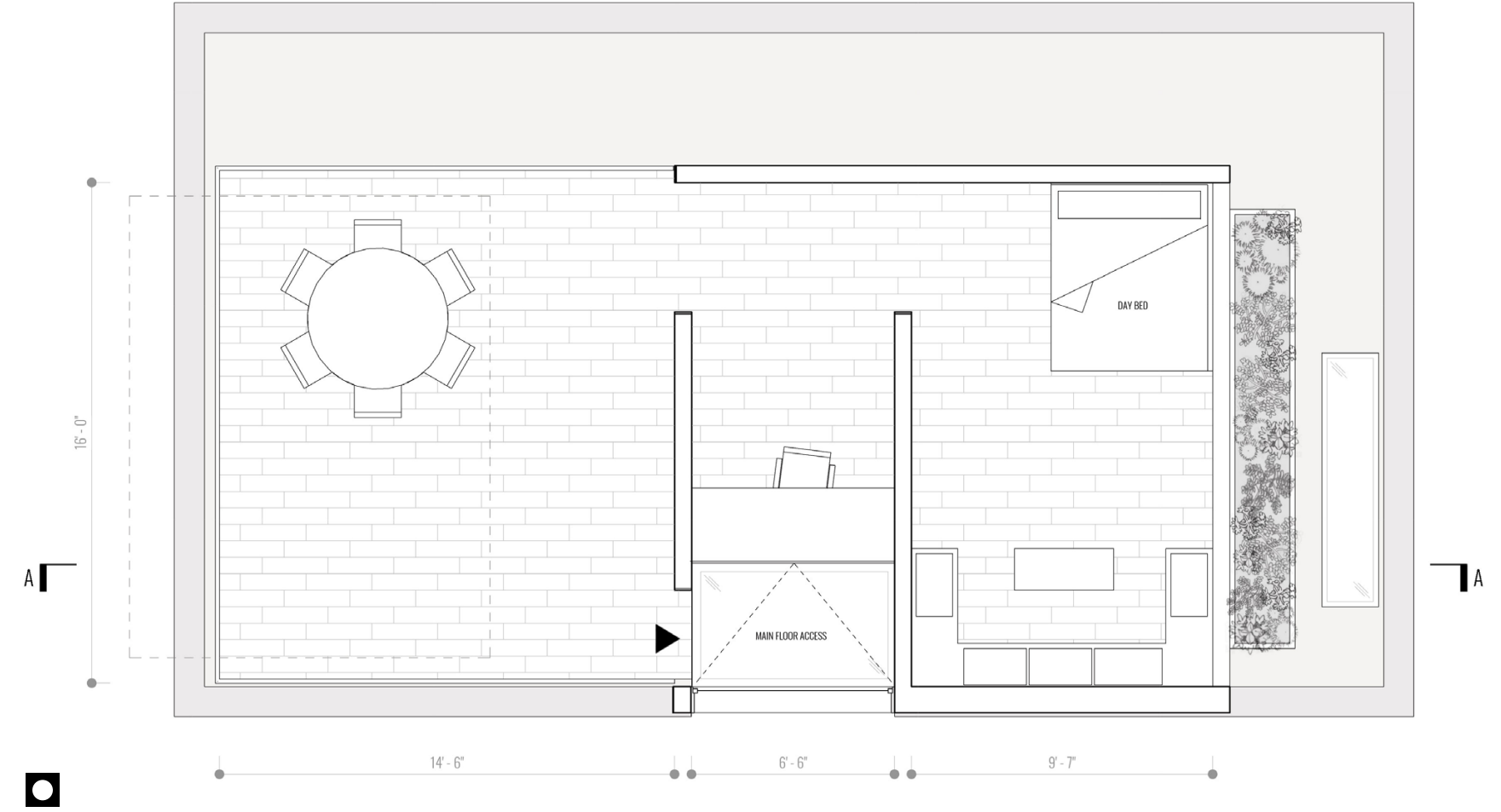
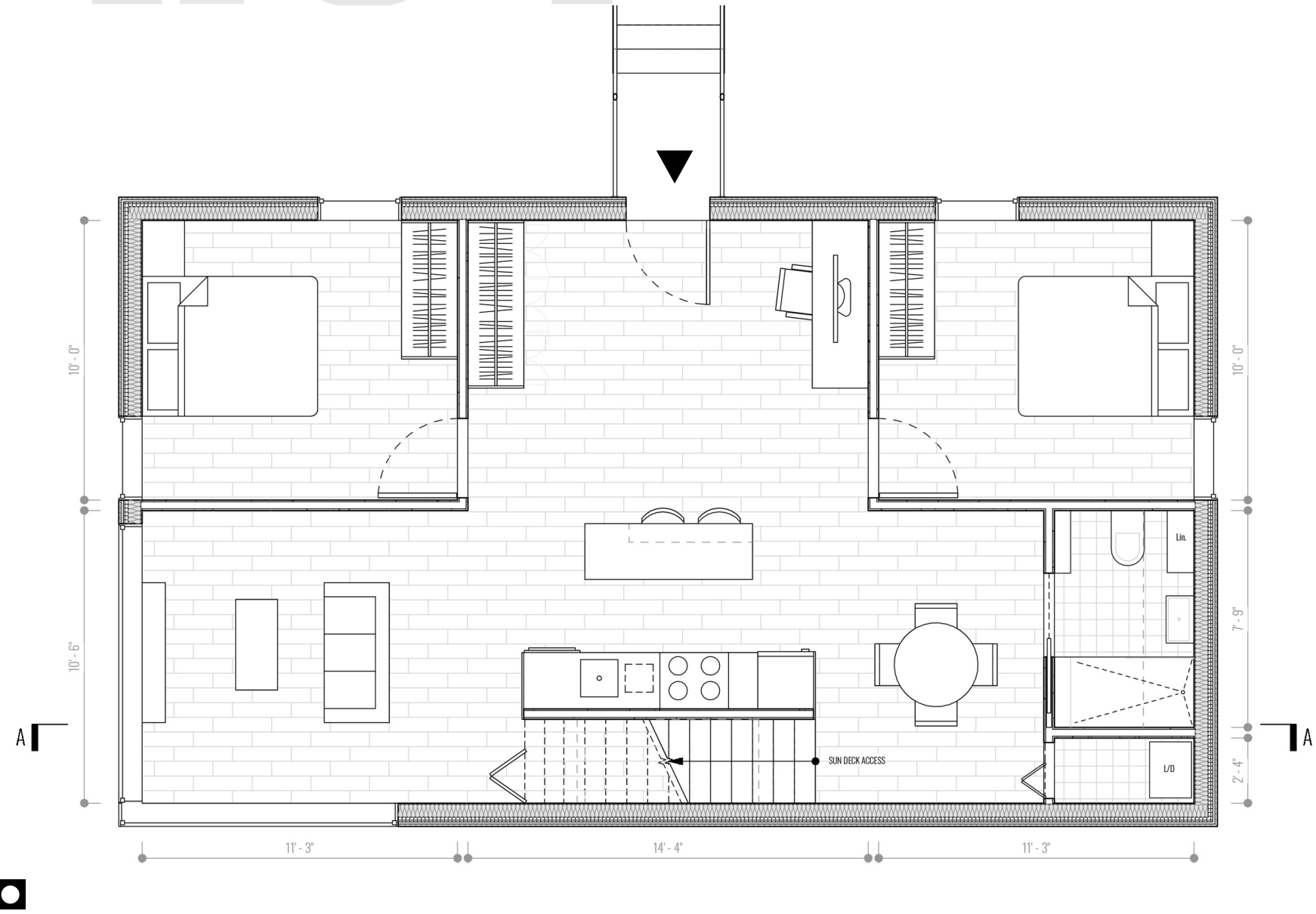

■ Main Level 2 Bedroom Plan

▲ Garden Level 3 Bedroom Plan

■ Roof Deck Plan

▲ Key Plan (unit entry into canopy)

A.01

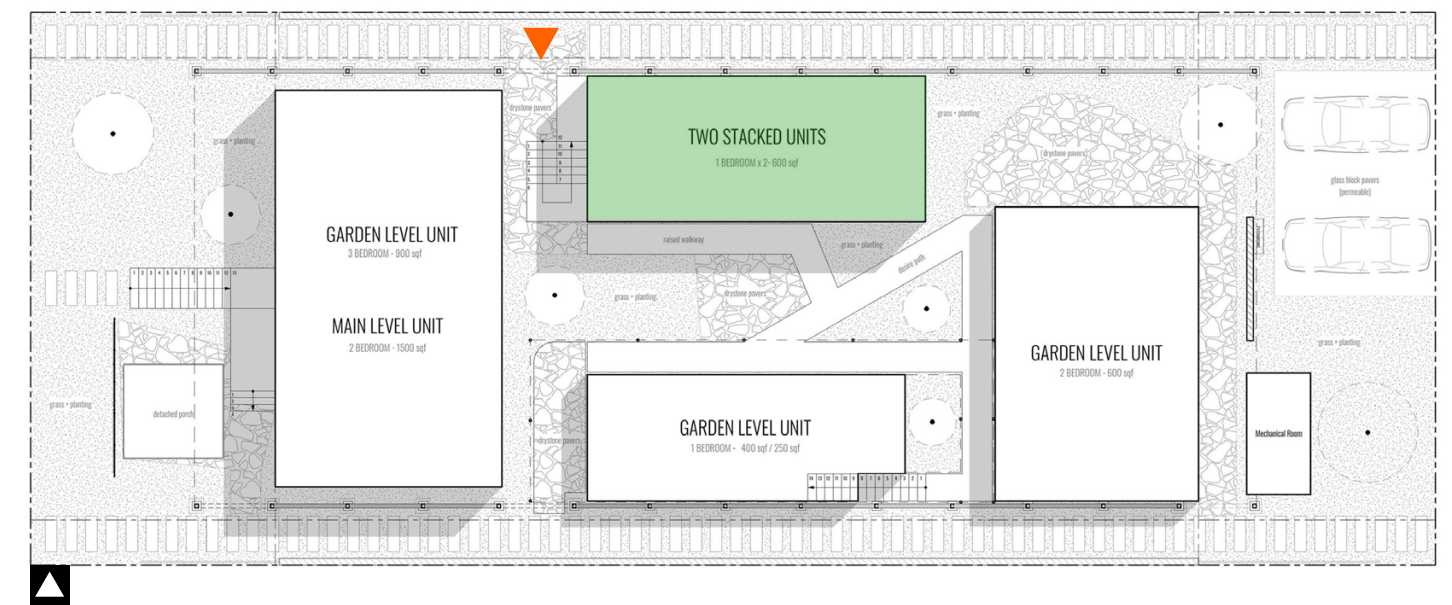
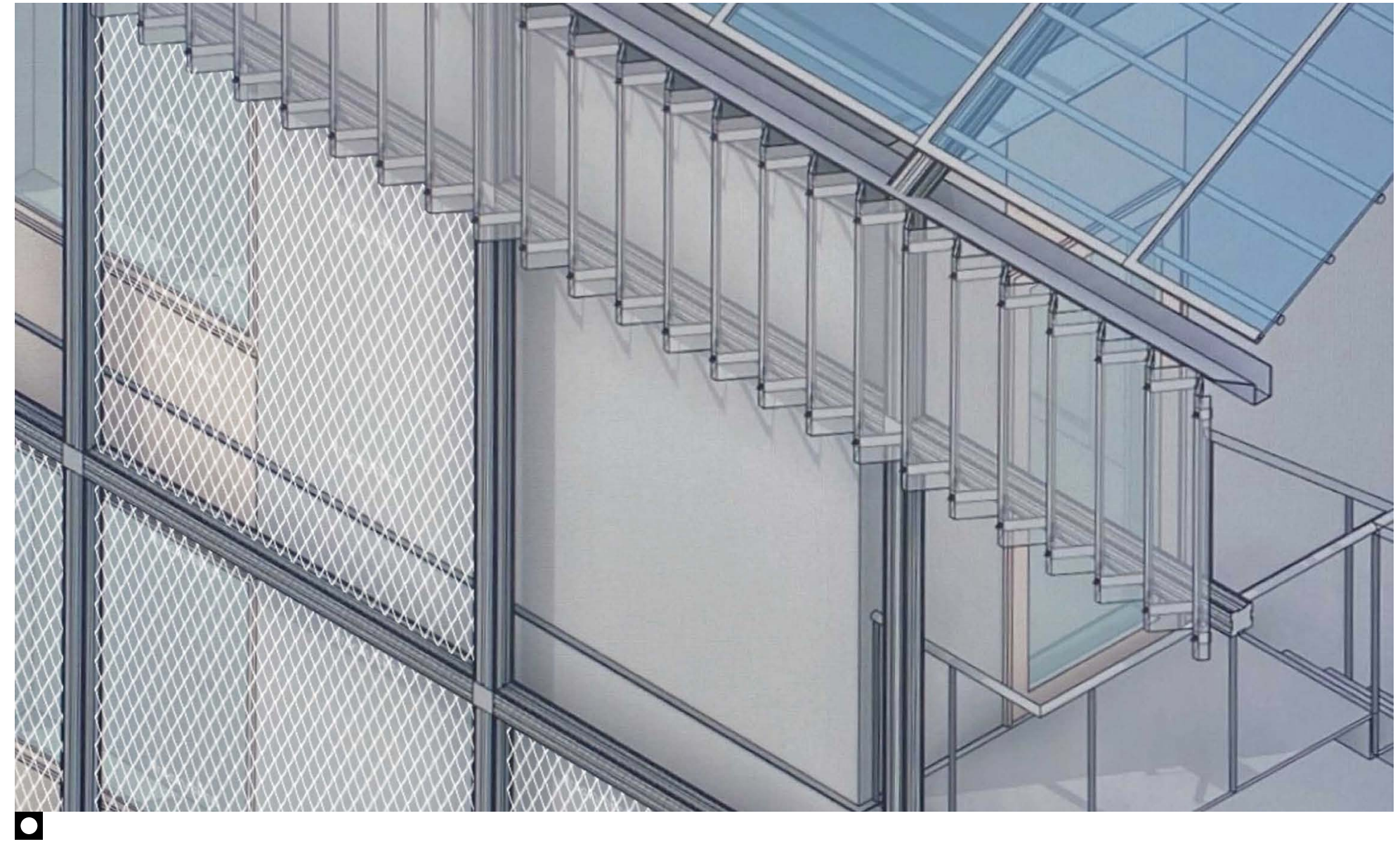
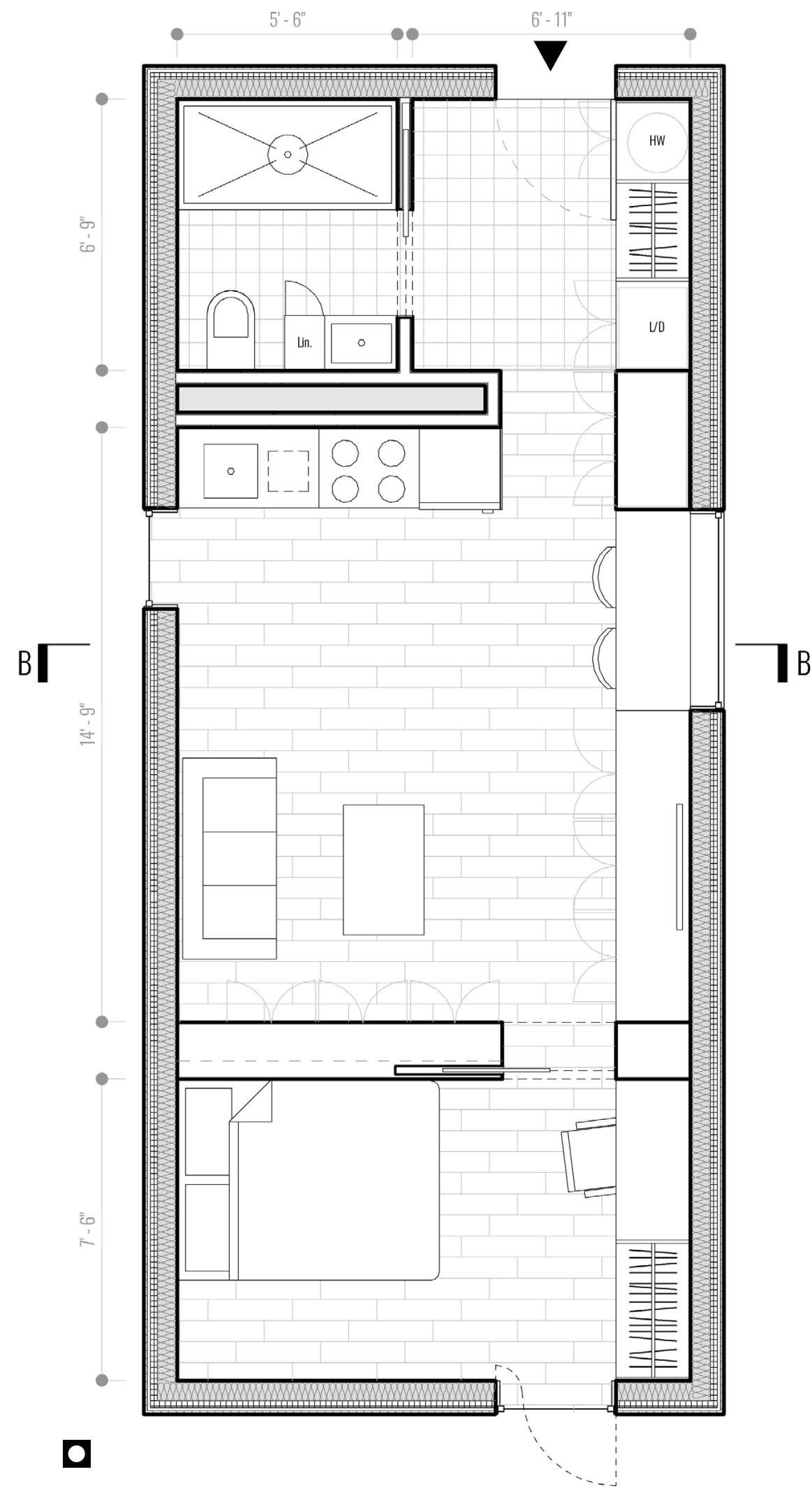

■ Stacked 1 Bedroom Plan

■ Digital Image

▲ Key Plan (unit entry into canopy)

A.01

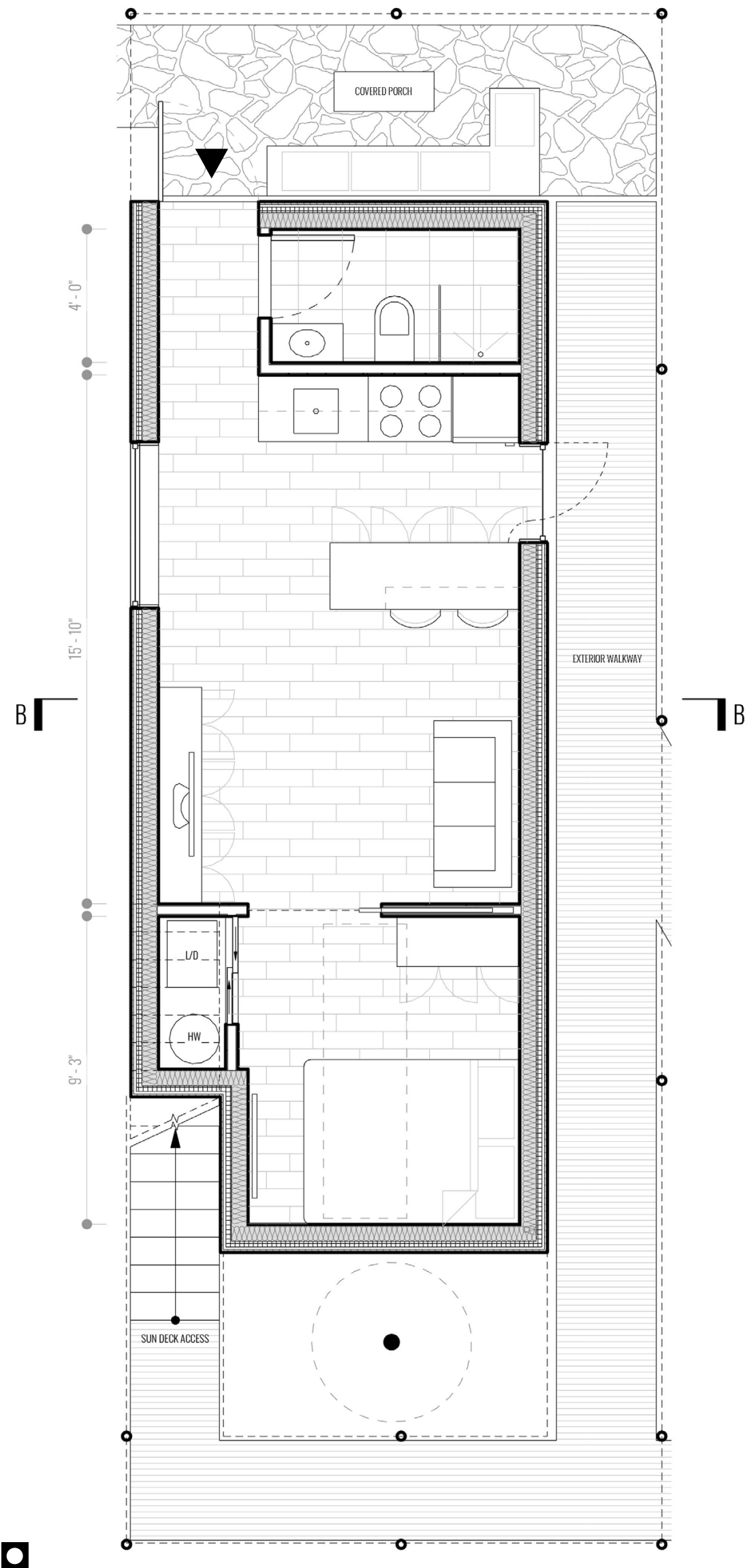

■ Studio w/ Sun Deck Plan



■ Roof Deck

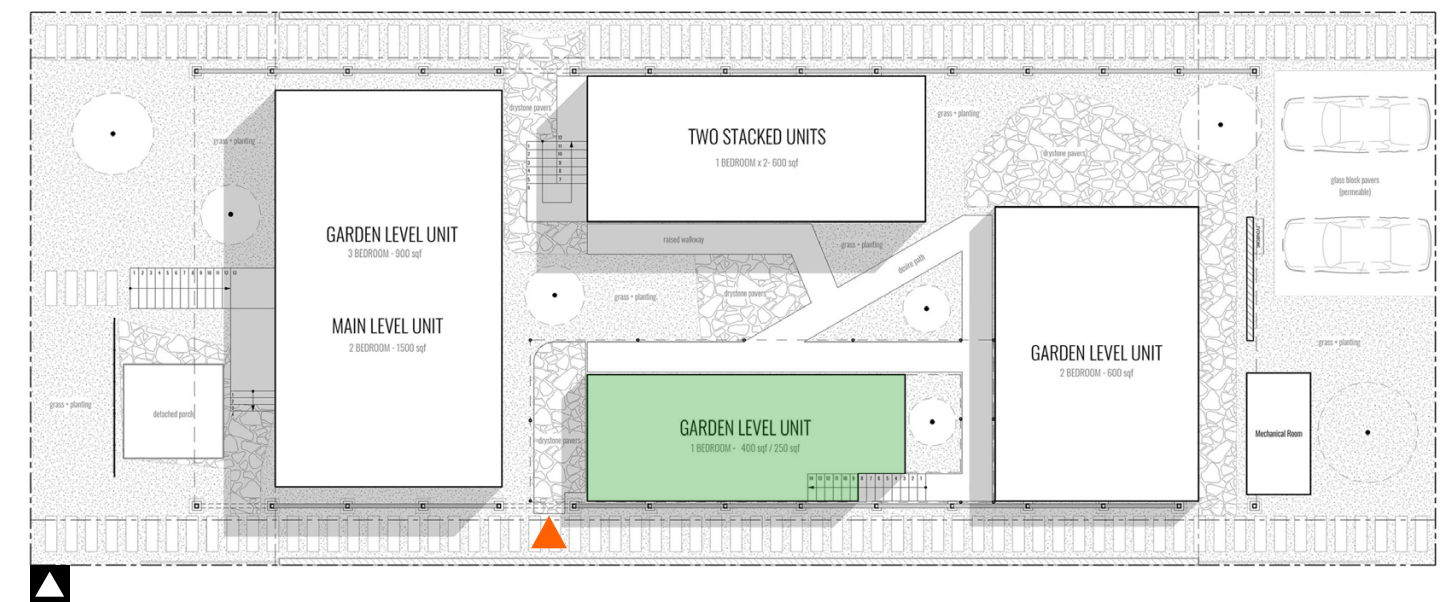

▲ Key Plan (unit entry into canopy)

A.01

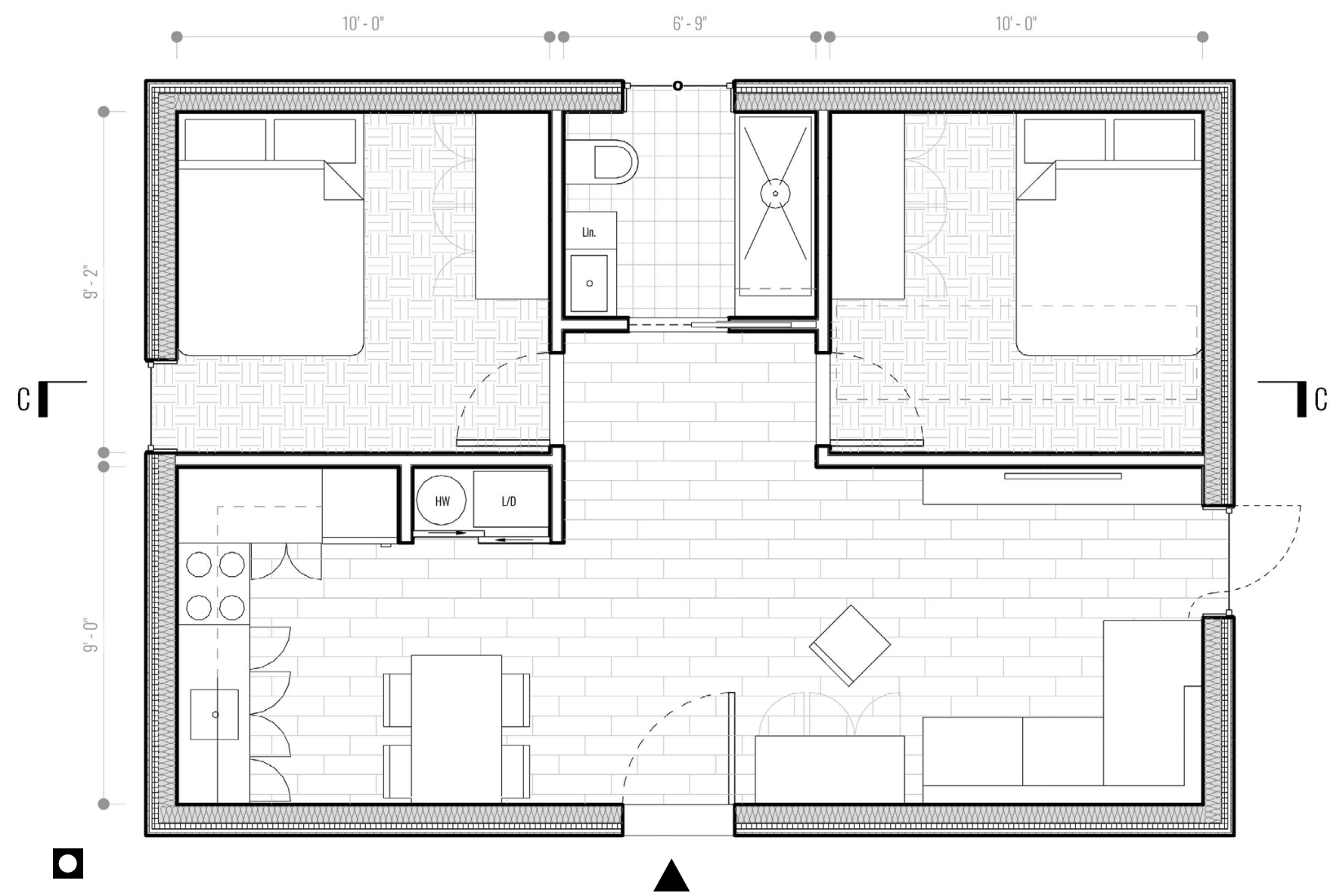

■ Garden Level 2 Bedroom Plan

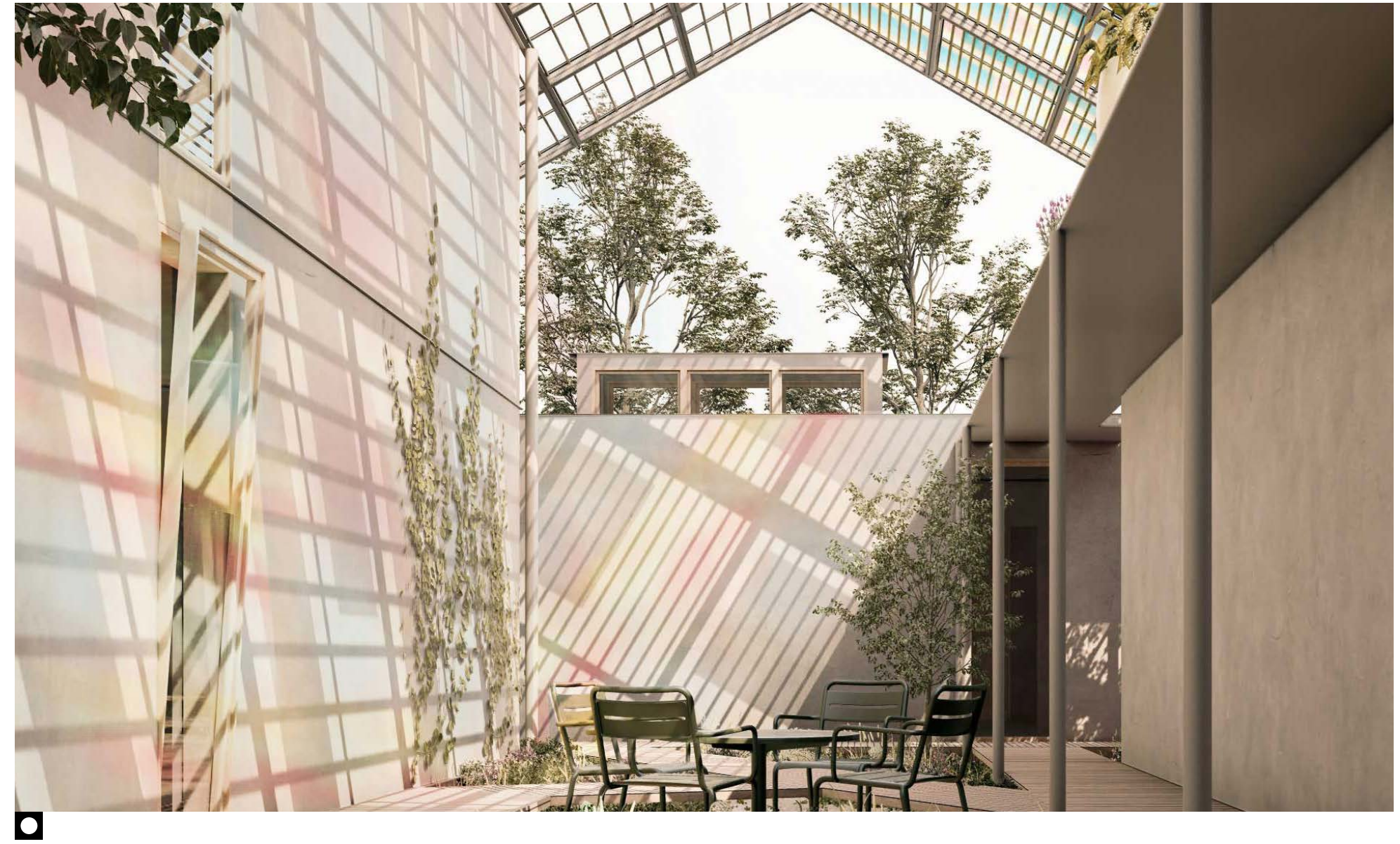

■ Digital Image

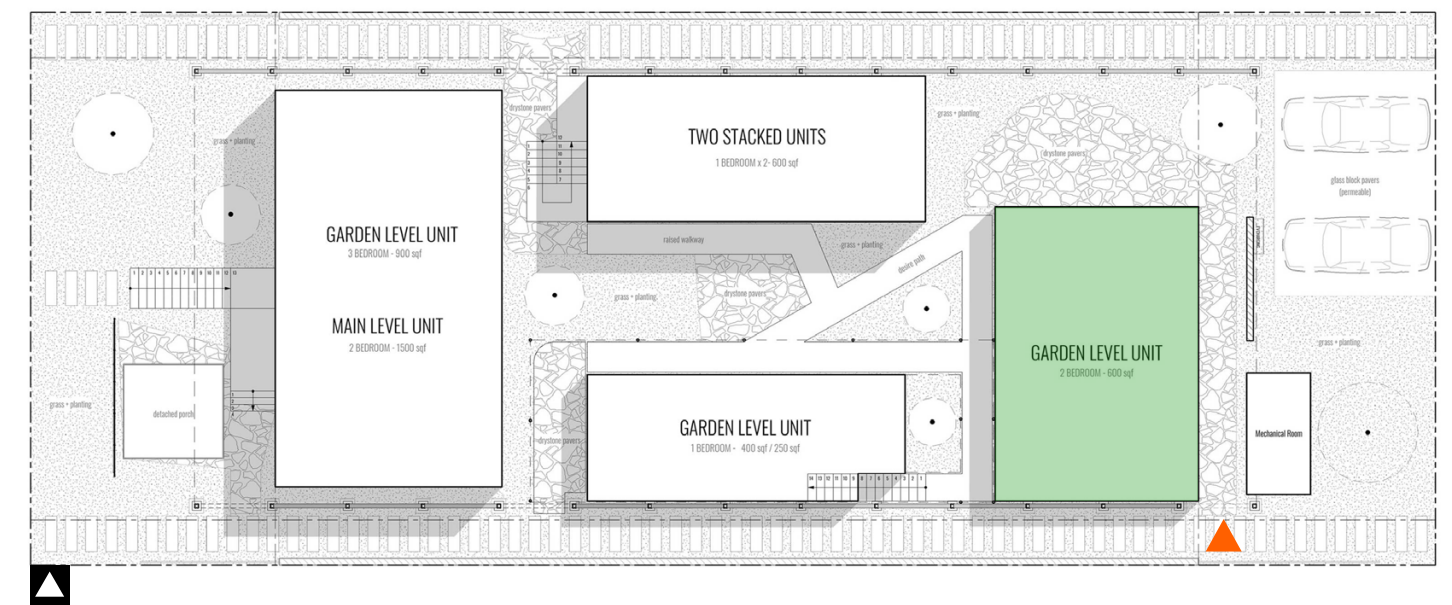

▲ Key Plan (unit entry into canopy)

A.01

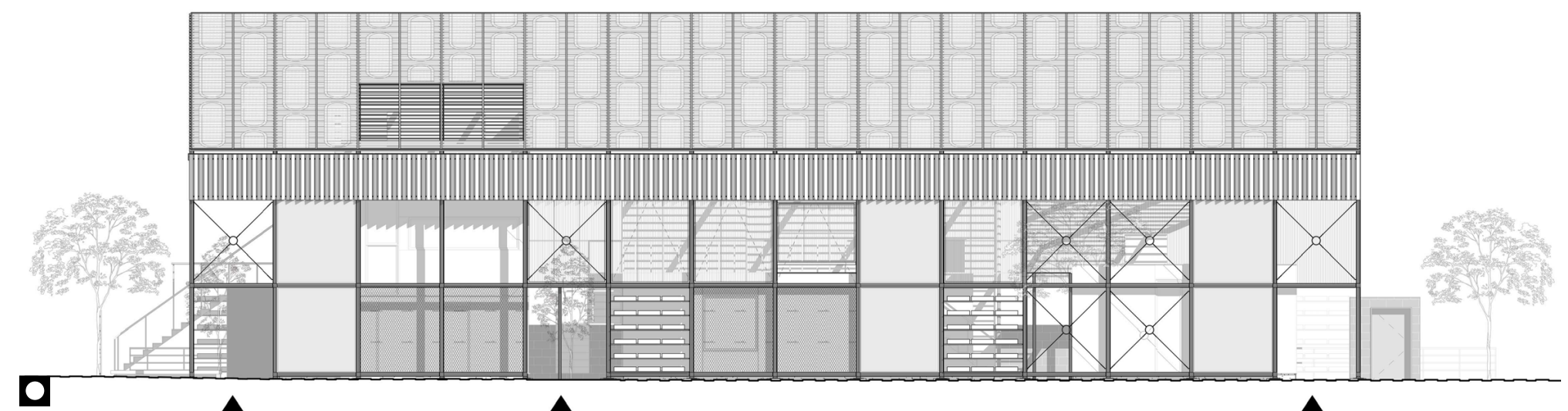
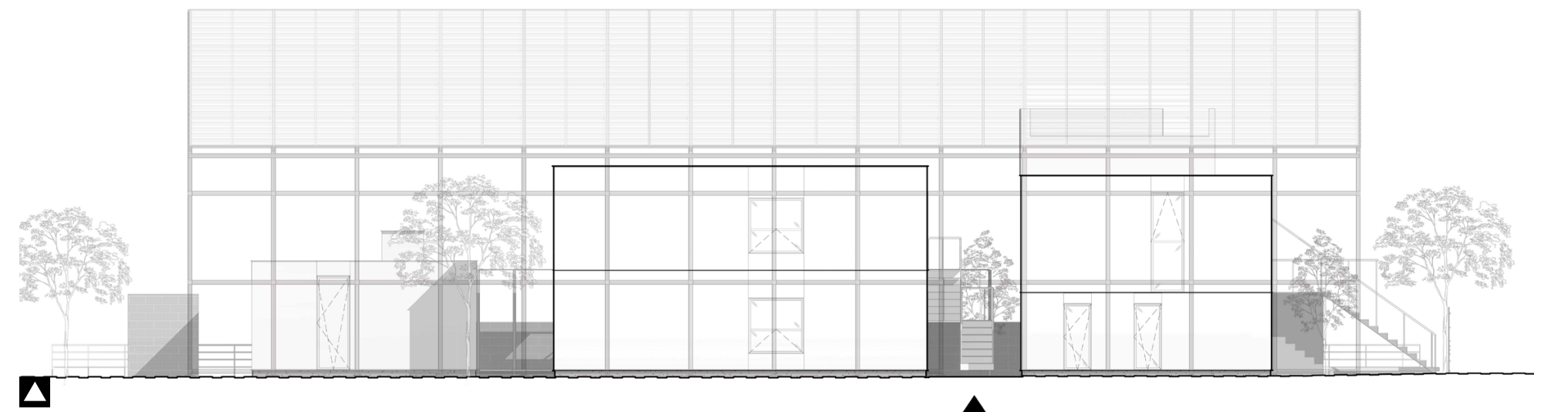
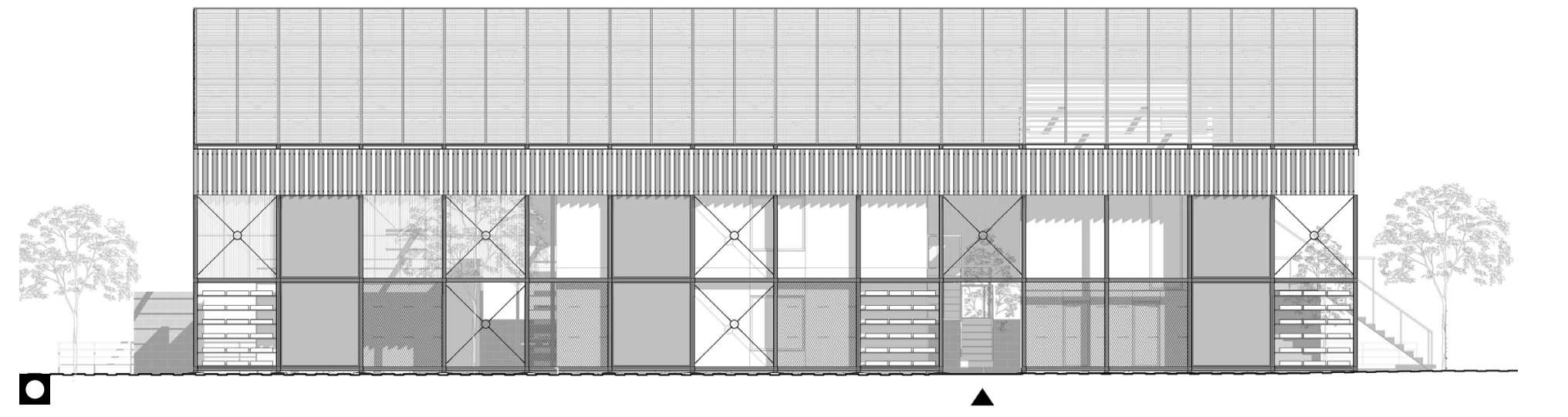
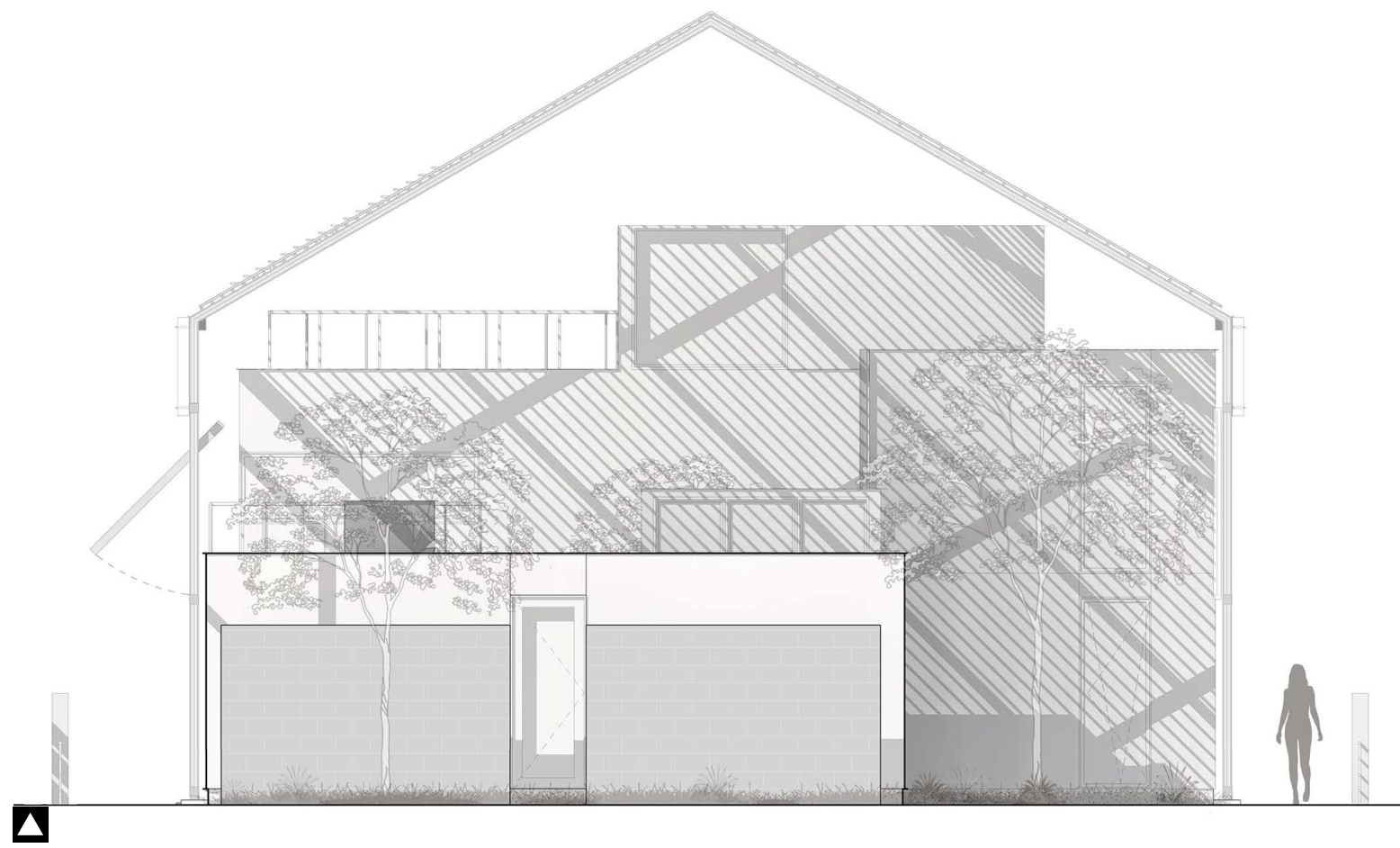

◻ North Elevation

◼ South Elevation

◻ Climate Canopy Elevations (east-west)

◼ Unit Elevations (east-west)

A.01

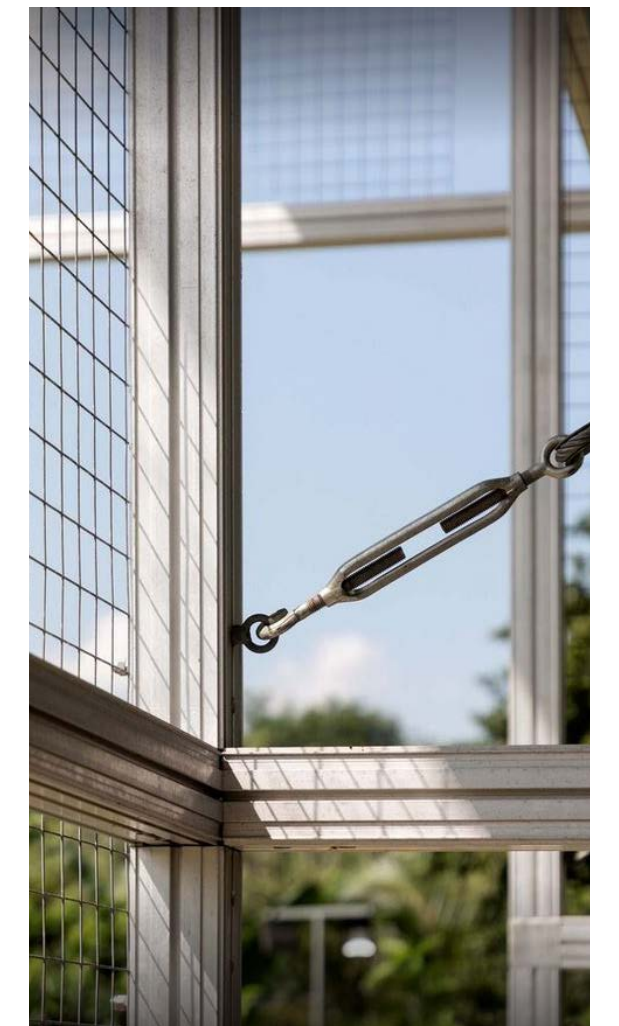
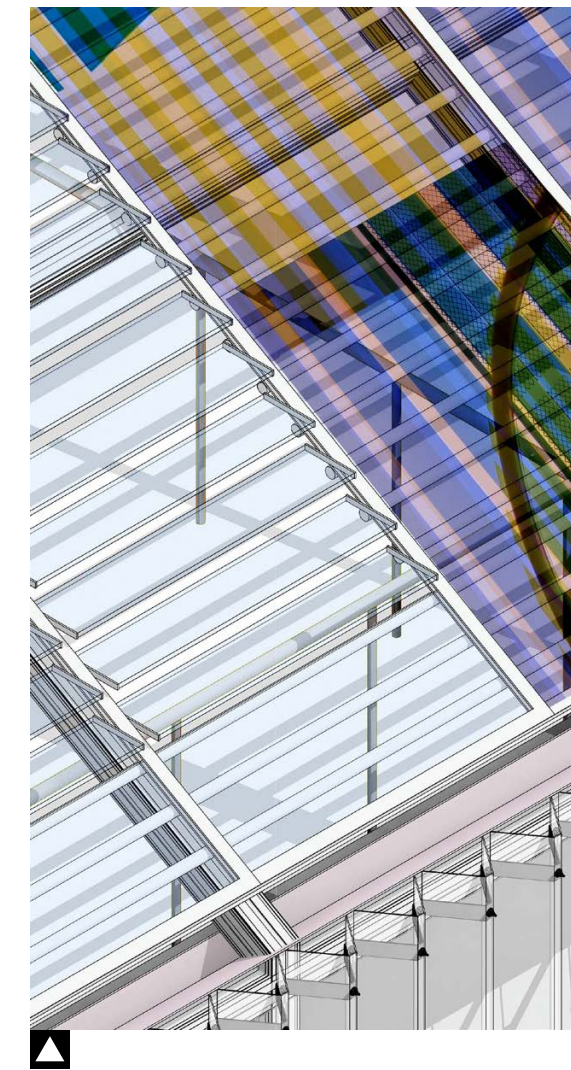
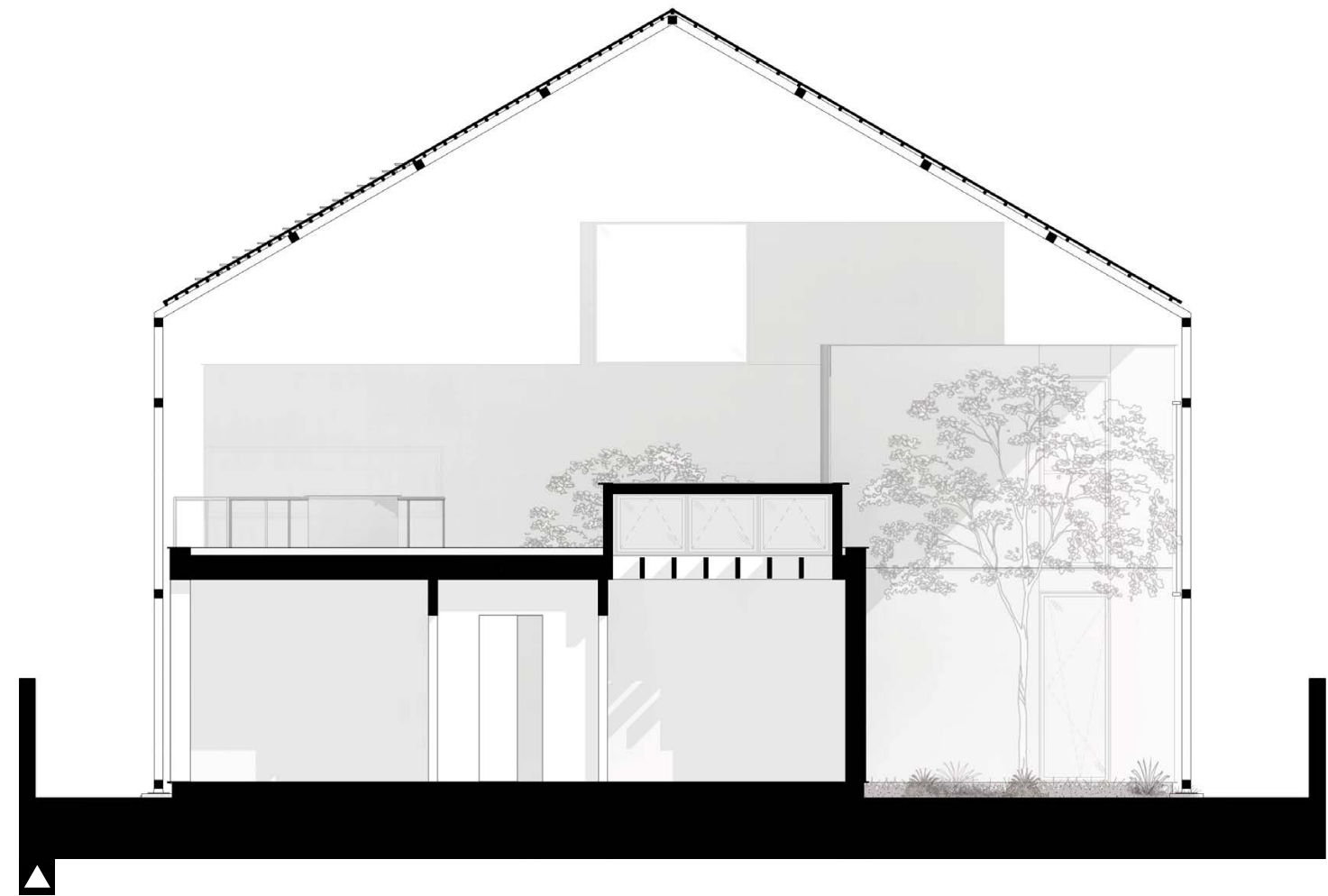
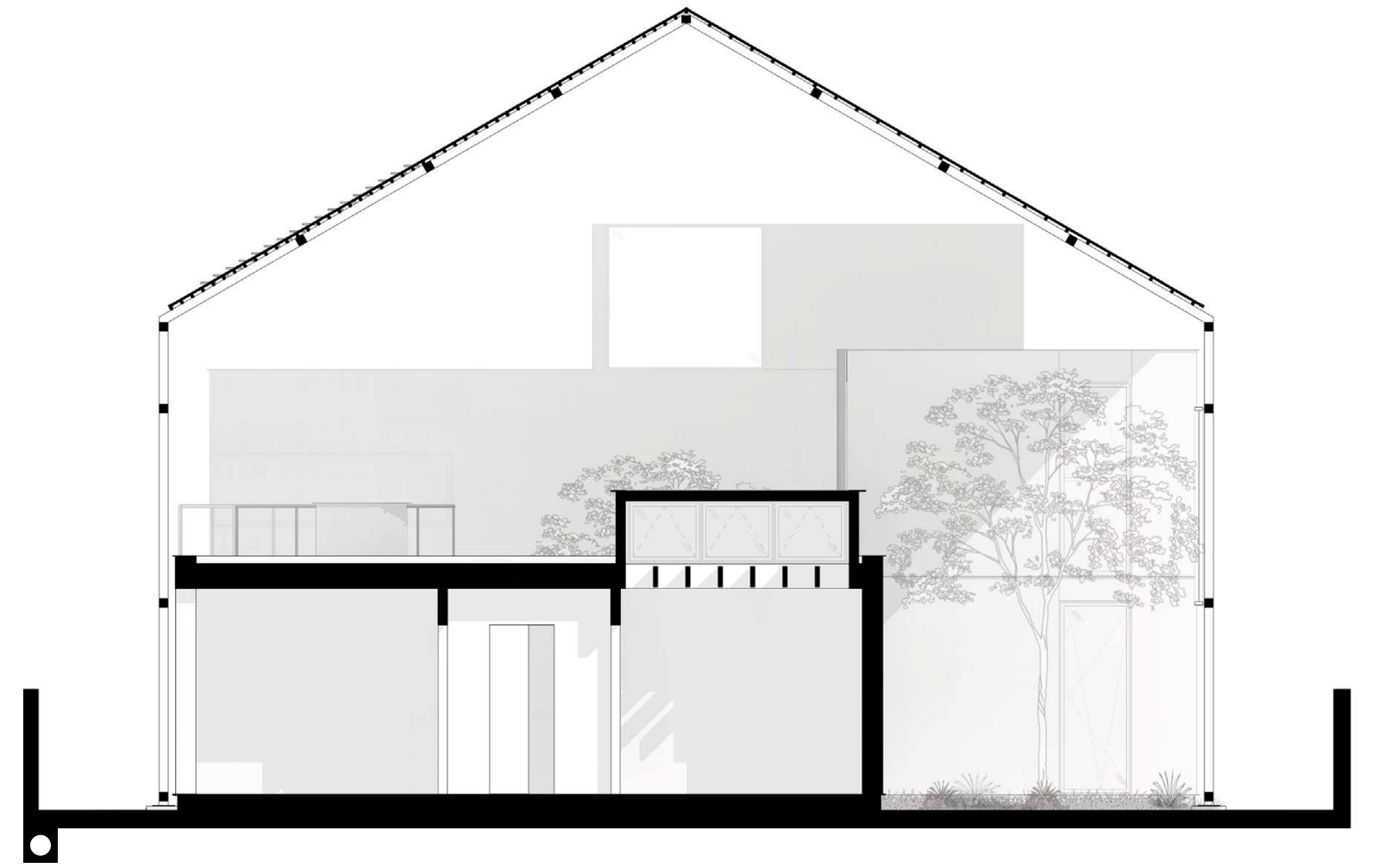
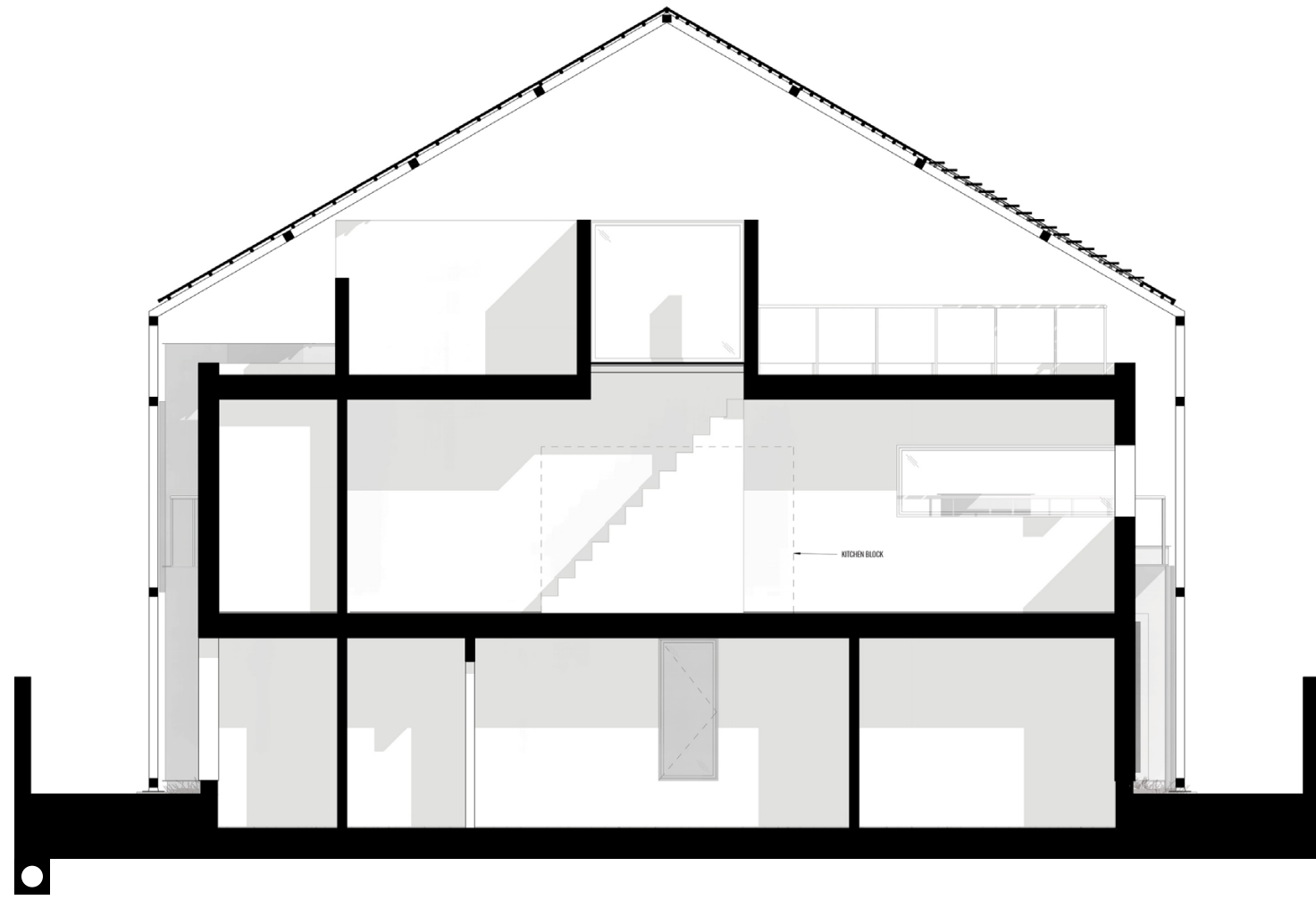

▣ Section A-A

▣ Section C-C

▣ Section B-B

▣ Digital Image of Graphic Solar Film (PET)

